

PARCS WING SERIES

OXYGEN FOR THE OFFICE

The shape of the Wing Series is based on traditional “wingback seats”. Lateral headrests provide a visual and acoustic shield and facilitate meetings that require concentration, focused work or recreation. To communicate to another person seated in a Wing Chair, just swivel them around to face each other,

to create a clear dialogue channel. If you do not wish to be disturbed simply turn them away. In the case of the American Diner two Wing Sofas are sociably positioned opposite from one another – ready for collaboration in small teams. At attractive space-within-space combination in two different heights.

Design: Pearson Lloyd



bene

INSPIRING OFFICES. SINCE 1790.

Exclusively distributed to transportation terminals in North America by **ARCONAS**

PRODUCT DESCRIPTION

Wing Sofa and American Diner consist of a wood frame substructure with dimensionally stable polyurethane foam padding and have plastic adjustment feet. The Wing Chair is made of moulded polyurethane foam with a metal frame substructure. With a swivel base plate that permits 360-degree swivelling.

All elements are available in different heights. Optionally in flame-resistant version according to BS 5852 Part 2, Ignition Source 5 (Crib 5). Covers always come with double stitching.

- ❶ **Head wings**
- ❷ **Head-rest**
- ❸ **Centre part**
- ❹ **Seat:** seat depth for the Wing Chair 450 mm; for the Wing Sofa and American Diner 460 mm.
- ❺ **Swivel base:** for the Wing Chair. Made of metal in SZ black, powder-coated.
- ❻ **Top connecting element:** for American Diner. Same design as head wings.
- ❼ **Bottom connecting element:** for American Diner. Same design as seat.

* American Diner

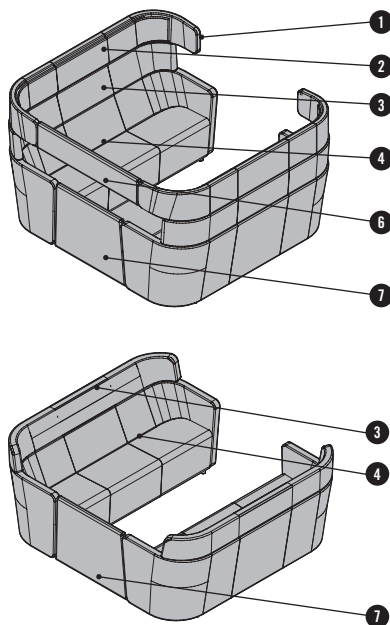

Wing Sofa

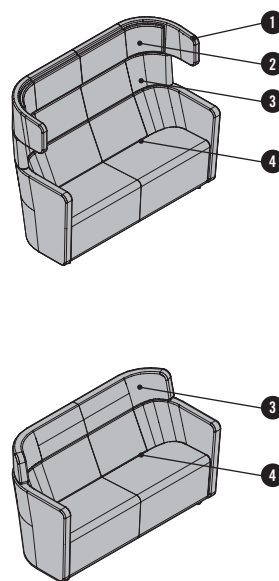

Wing Chair

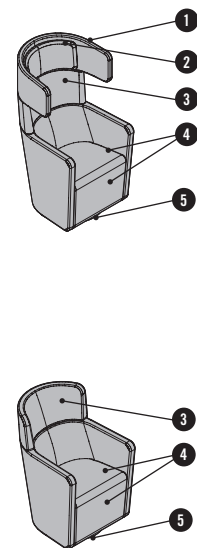

*American Diner high can also be chosen in the closed variant.

OVERVIEW & DIMENSIONS

AMERICAN DINER

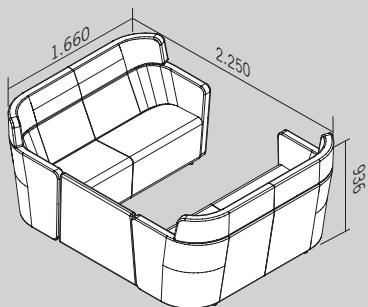
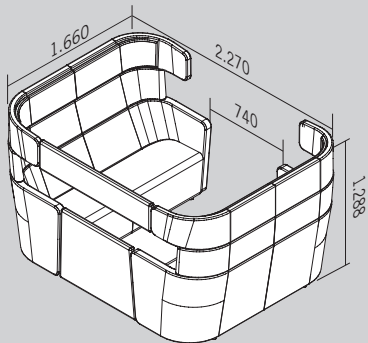
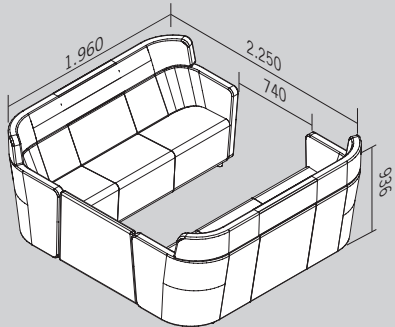
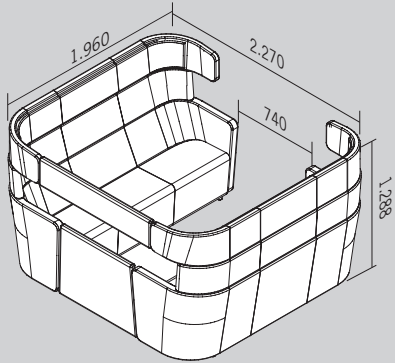

WING SOFA

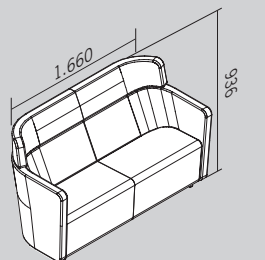
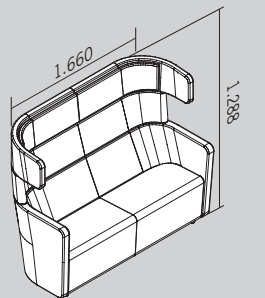
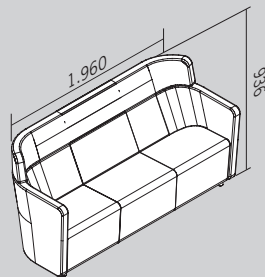
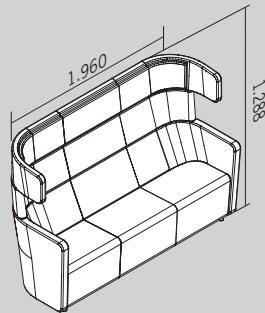

WING CHAIR

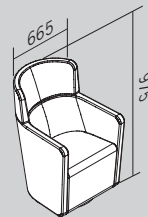
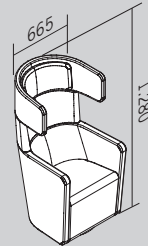

Measurements in mm

OPTIONS

PREPARATION FOR CONNECTION PLUG BOARD - AMERICAN DINER

The bottom connecting element of the American Diner can optionally be equipped with a flush-mounted connection plug board with a peripheral AL anodised aluminium panel.

Choose between a Bachmann connection plug board with a Bene end cap, the model with four power sockets, or three power sockets and two RJ45 CAT6 jacks. The cable runs invisibly through the connecting element. The recommended starter cable length is 5.000 mm.

The connection plug boards and cables must be ordered separately.

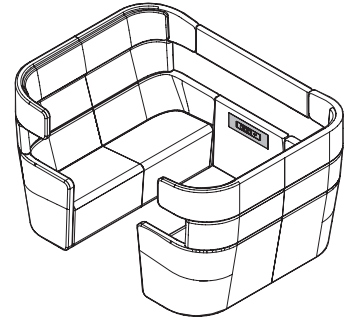

PREPARATION FOR A SCREEN CONNECTION

The closed American Diner prepared for screen connection.

Prepared for Screen 32 inch NEC MultiSync M321.
(must be ordered separately and is upgradeable)

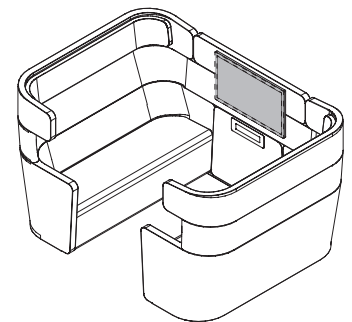

WING CHAIR ATTACHMENT TABLE

Optionally mountable on a Wing Chair. The attachment table can be rotated and swiveled. Table top with compact top 13 mm, on steel bracket in SZ black, powder-coated. Maximum load 10 kg. Dimensions: width 300 mm, depth 420 mm

Colours based on the Bene collection in melamine group 1 and group 2.

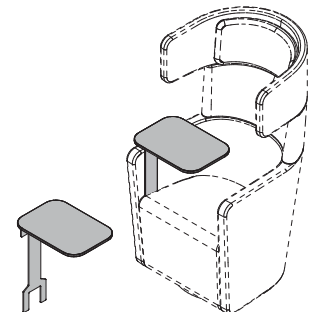

INSPIRATIONS



American Diner closed with integrated screen
and Club Table Big.



Wing Chair high with Cylinder Table and Pop-up Stool.

COLOURS & MATERIALS



Various fabric and leather collections are available for the cover: Era, Urban Plus, Xtreme Plus, Rondo, Step, Step Melange, Remix, Europost, Mainline Flex, Steelcut, Fox, Fiord, Hallingdal, Steelcut Trio, Divina Melange, Divina MD, Greenwich Uni, Entrée, Entrée Color and Superior. More information about the specific fabric and leather collections is available at www.bene.com.

BENE WORKS SUSTAINABLY

Bene plays a leading role in responsible environmental management. This policy is practised throughout all company divisions – from product development, procurement, production and logistics to product recycling. Bene considers ecology to be a central element of its responsible and sustainable corporate strategy. Bene sees the legal regulations as minimum requirements and strives for better and more sustainable environmental protection throughout the group. Bene's environmental policy principle is: **Avoidance – Minimisation – Recycling – Disposal.**

PARCS WING CHAIR - ECOLOGICAL STANDARDS

- 99% recyclable
- 25.70% renewable raw materials
- Resource-conserving product design
- Use of materials tested for presence of hazardous substances
- No PVCs, chromium, lead or mercury
- Individual parts can be sorted according to homogeneous categories
- Recyclable, with a positive contribution to the carbon footprint(average 15.50 kg CO₂)

PARCS WING CHAIR LEED POINTS

Leadership in Energy and Environmental Design (LEED) is a system developed by the U.S. Green Building Council to classify ecological construction. As an internationally recognised standard, LEED sets out numerous guidelines for environmentally friendly, resource-efficient, and sustainable construction. The use of PARCS Wing Chair is an important contribution to LEED certification. The following criteria for this are from »LEED 2009 for Commercial Interiors«:

MR Credit 4	Recycled content	up to 2 points
MR Credit 5	Regional materials	up to 2 points
IEQ Credit 4.5	Material with low hazardous substance content	up to 1 point

PARCS WING CHAIR MATERIAL COMPONENTS

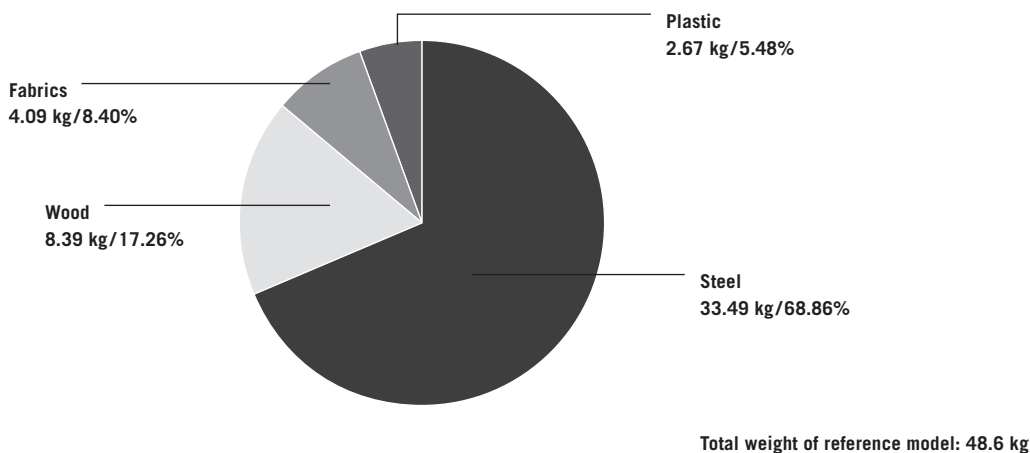

Environment-related information about Bene: www.bene.com/sustainability



The mark of responsible forestry
(on request)