

# PARCS TOGUNA

## OXYGEN FOR THE OFFICE

Circular or square-shaped the PARCS Toguna is a semi-secluded meeting place for open spaces. Its striking shape brings a strong visual statement to any office. The Toguna represents a break from

rigid structures that encourages openness and movement, making it perfect for brainstorming sessions or short informal meetings.

**Design: Pearson Lloyd**



**bene**

**INSPIRING OFFICES. SINCE 1790.**

Exclusively distributed to transportation terminals in North America by **ARCONAS**

## PRODUCT DESCRIPTION

The Toguna comprises of a wooden substructure with dimensionally stable in flame-resistant version according to BS 5852 Part 2, Ignition Source 5 (Crib 5). A supportive metal rod structure is screwed into the steel ring base and top frame. A two piece MDF plate rests on the floor, with cabling concealed beneath an optional rug. The outer rim of the roof element is upholstered. Covers are always double stitched.

### TOGUNA LOW AND TOGUNA HIGH

- 1 Roof
- 2 Rim: Is always in the same style as the top ring.
- 3 Top ring
- 4 Middle ring
- 5 Bottom ring
- 6 Rug: Comes in two versions, Forma and Poodle, in natural, slate grey or black.
- 7 Metal floor ring: in SZ black, powder-coated

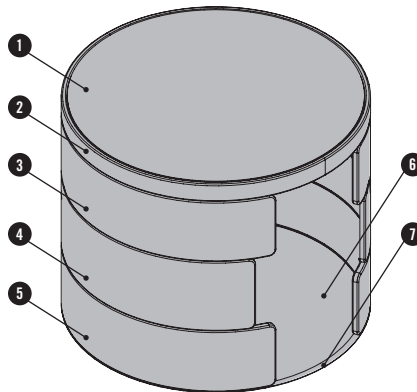

#### Configuration options:

- Single-coloured
- Inside and outside colours different

### TOGUNA SQUARE

The Toguna Square can be configured with one or two entrances. The two entrances are always positioned opposite one another. The Toguna with one entrance can be specified without a floor plate.

- 1 Roof
- 2 Rim: Is always in the same style as the top ring.
- 3 Top ring
- 4 Middle ring
- 5 Bottom ring
- 6 Rug: Comes in two versions, Forma and Poodle, in natural, slate grey or black.
- 7 Metal floor ring: in SZ black, powder-coated

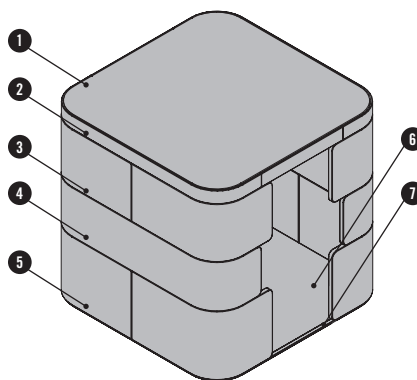

#### Configuration options:

- Single-coloured
- Inside and outside colours different

## PRODUCT DESCRIPTION

### TOGUNA CIRCLE

The Toguna Circle can be configured with one entrance or two.  
The two entrances are always positioned opposite one another.  
The Toguna Circle with one entrance can be specified without a floor.

- 1 Top ring
- 2 Bottom ring
- 3 Rug: Comes in two versions, Forma in slate grey or black and Poodle, in natural, slate grey or black.
- 4 Metal floor ring: in SZ black, powder-coated

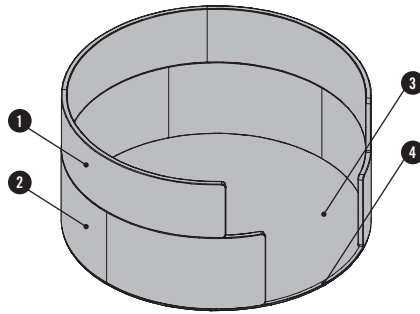

**Configuration options:**

- Single-coloured
- Inside and outside colours different

---

### TOGUNA CIRCLE SMALL

The Toguna Circle Small comes bench. The Bench version can be chosen independent of the rings.

- 1 Top ring
- 2 Bottom ring
- 3 Bench: Substructure padded with polyurethane foam, metal base frame made of CR chrome. Seat depth: 470 mm
- 4 Metal floor ring: in SZ black, powder-coated

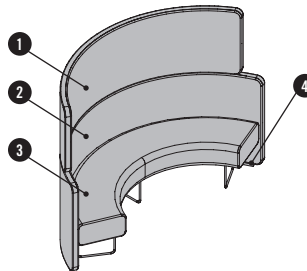

**Configuration options:**

- Single-coloured
- Inside and outside colours different

## OVERVIEW & DIMENSIONS

**TOGUNA LOW**

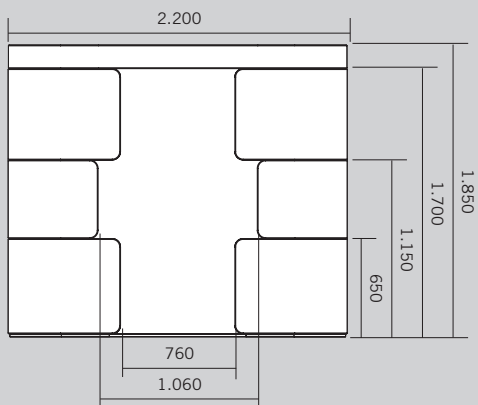

**TOGUNA HIGH**

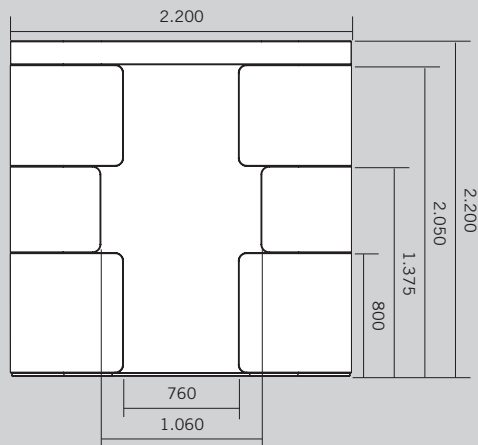

**TOGUNA SQUARE**

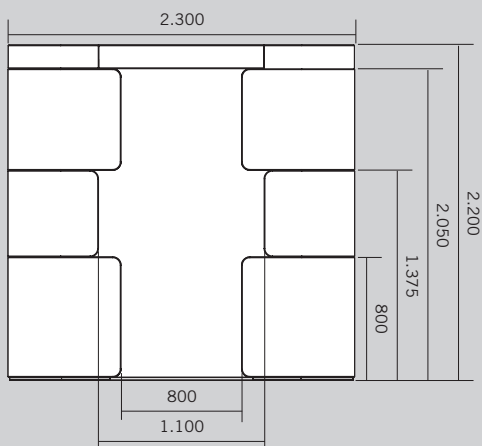

**TOGUNA CIRCLE**

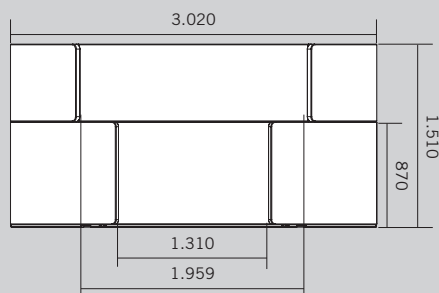

**TOGUNA CIRCLE SMALL**

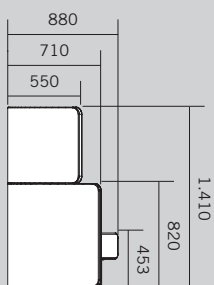

Measurements in mm

## OPTIONS

### LIGHTING FOR TOGUNA LOW, TOGUNA HIGH AND TOGUNA SQUARE

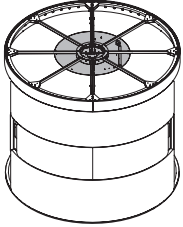

Roof with integrated lighting, consisting of 8 LED strips (4.000 K) arranged in a circular fashion. They are switched on via remote buttons (dimnable) or motion detector (not dimmable). Light canopy at the bottom and top of the roof in Trevira CS.

### PERCH FOR TOGUNA LOW, TOGUNA HIGH AND TOGUNA SQUARE

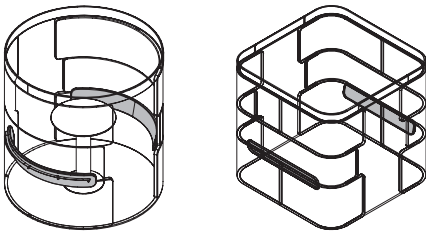

The perch is made of a shaped wood base plate, upholstered with dimensionally stable, flame-resistant polyurethane foam padding. It can be hooked into the Toguna high or Toguna Square support structure between the middle and bottom ring. Covers always come with double stitching.

Covers are available in all fabrics in price groups P0-P4 from the Bene seating furniture collection.

### BENCH FOR TOGUNA LOW AND TOGUNA HIGH

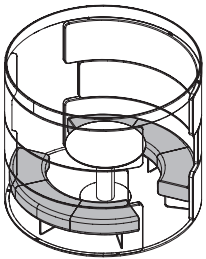

The bench for Toguna low/high consists of a substructure with padded with polyurethane foam. Metal frame in SZ black, powder-coated. Width 1.940 mm, depth 470 mm. Covers always come with double stitching. Optionally in flame-resistant version according to BS 5852 Part 2, Ignition Source 5 (Crib 5).

Covers are available in all fabrics in price groups P0-P4, from the Bene seating furniture collection. This bench can only be used in combination with a Toguna Low/High.

### BENCH FOR TOGUNA CIRCLE

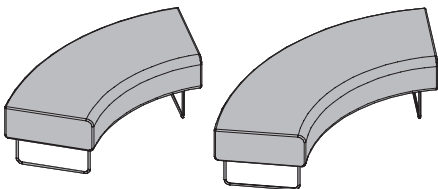

Depending on the configuration, 60° or 75° bench elements can be used in the Toguna Circle. Each Toguna can only be designed with benches of the same type. The bench for Toguna Circle consists of a substructure padded with polyurethane foam in flame-resistant version according to BS 5852 Part 2, Ignition Source 5 (Crib 5). Metal base frame made of CR chrome. Covers always come with double stitching.

Covers are available in all fabrics in price groups P0-P4, from the Bene seating furniture collection. This bench can only be used together with a Toguna Circle. To avoid tipping at least 2 benches must be connected to each other.

### CUSHIONS

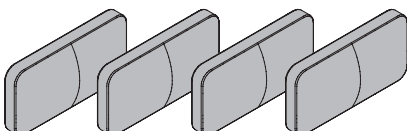

Cushions can be ordered separately or in sets of up to 4 pillows (in the same design). Width 640 mm, Depth 320 mm, Height 160 mm. Cushions have a fire-retardant synthetic filling and a fabric cover.

Covers are available in the range of fabrics included in price groups P2-P4.

## INSPIRATIONS

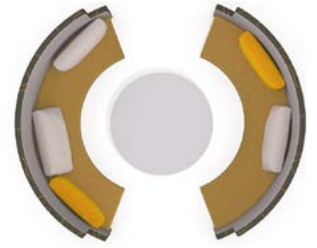

2x Toguna circle small with Club Table.  
Measurements: Ø 2.2 m



Toguna high with perch and lighting including Toguna Table.

## COLOURS & MATERIALS



Various fabric collections are available for the cover: Era, Xtreme Plus, Rondo, Remix, Europost, Mainline Flex, Fox, Fiord, Steelcut, Stamskin Top, Hallingdal, Steelcut Trio, Divina Melange, Divina MD, Greenwich, Greenwich Uni. More information about the specific fabric collections is available at [www.bene.com](http://www.bene.com).

## BENE WORKS SUSTAINABLY

Bene plays a leading role in responsible environmental management. This policy is practised throughout all company divisions – from product development, procurement, production and logistics to product recycling. Bene considers ecology to be a central element of its responsible and sustainable corporate strategy. Bene sees the legal regulations as minimum requirements and strives for better and more sustainable environmental protection throughout the group. Bene's environmental policy principle is: **Avoidance – Minimisation – Recycling – Disposal.**

### PARCS TOGUNA - ECOLOGICAL STANDARDS

- 99.80% recyclable
- 65.10% renewable raw materials
- 28.20% use of recycled product materials (18.31% post-consumer, 9.89% pre-consumer)
- 22.57% use of recycled product materials that comply with LEED (18.31% post-consumer, 9.89% pre-consumer)
- Resource-conserving product design
- Use of certified wood (chain of custody)
- Use of materials tested for presence of hazardous substances
- No PVCs, chromium, lead or mercury
- Individual parts can be sorted according to homogeneous categories
- Recyclable, with a positive contribution to the carbon footprint(average 365.80 kg CO<sub>2</sub>)

## PARCS TOGUNA LEED POINTS

Leadership in Energy and Environmental Design (LEED) is a system developed by the U.S. Green Building Council to classify ecological construction. As an internationally recognised standard, LEED sets out numerous guidelines for environmentally friendly, resource-efficient, and sustainable construction. The use of PARCS Toguna is an important contribution to LEED certification. The following criteria for this are from »LEED 2009 for Commercial Interiors«:

MR Credit 4	Recycled content	up to 2 points
MR Credit 5	Regional materials	up to 2 points
MR Credit 7	Certified wood	up to 1 point
IEQ Credit 4.5	Material with low hazardous substance content	up to 1 point

### PARCS TOGUNA MATERIAL COMPONENTS

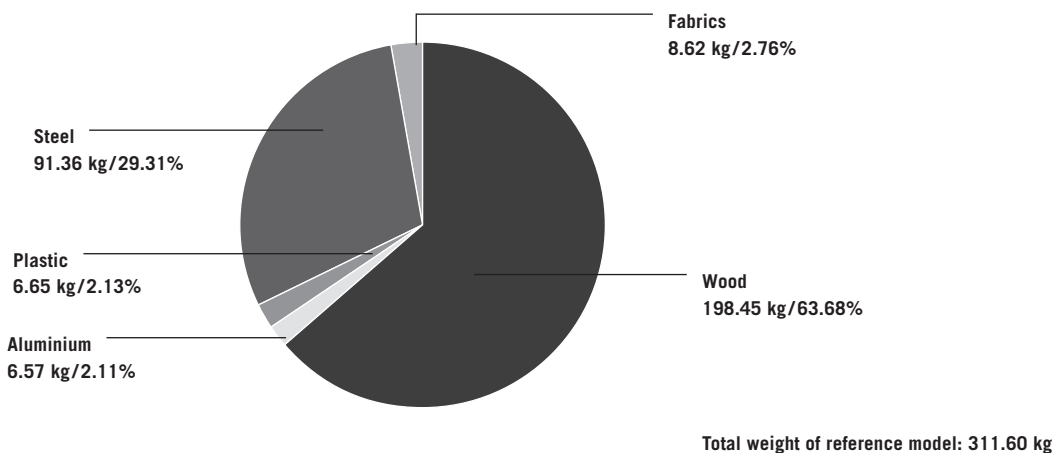

Environment-related information about Bene: [www.bene.com/sustainability](http://www.bene.com/sustainability)



The mark of responsible forestry  
(on request)